

On Premise Non-Metered Commercial Washer



Featuring Mechanical Controls



GCAM2792TQ 27" 2-Speed Non Metered Washer

- 3.2 Cu. Ft. Wash Basket, 18 Lbs. UL
- Push-Button Controls
- High-Efficiency, Low Water Factor
- 8 Cycles Options
- Two Water Levels
- Two-Speed Advantage with True Gentle Wash, High Speed Only
- Deep Rinse System
- Powdered Paint Top and Lid, Stainless Steel Hinges and Plated Console Screws
- Galvanized, Heavy Gauge Cabinet Back, Side and Front Panels, Removable Front Service Panel
- High Speed Spin—640 RPM (approximate)
- 1/2-HP Motor with Built-In Overload Protector: 120-Volt, 60 Hz., A.C. Agitation Speed 180 SPM/High 120 SPM/Low
- Heavy Duty Motor Coupler Isolator Tested to 20,000 Cycles*
- Extra-Long Power Cord, Water Inlet Hoses with Brass Couplings and Corrugated Drain Hose Included
- **2 Year Limited Parts Only Warranty****

*Testing completed 11/12/2001

**Call 1-800-NO-BELTS for warranty details.



FOR YOUR CUSTOMERS

- Large Capacity Wash Basket is Ideal for Family-Size Loads
- 8 Cycle Options: Regular/Super, Regular/Heavy, Regular/Normal, Regular/Light, Permanent Press/Normal, Permanent Press/Light, Gentle and Extra Rinse
- Bleach and Fabric Softener Dispensers

DIRECT DRIVE SYSTEM

- 27" Heavy-Duty Commercial Washer Feature the Reliable Direct-Drive, No-Belt Washing System for Greater Reliability, Reduced Downtime and Increased Profits
- Front and Bottom Serviceable

TRIPOD SUSPENSION

Sturdy tripod-suspension with active liquid filled balance ring reduces product weight while balancing commercial size laundry loads.



SEALED HIDDEN LID SWITCH

To help ensure safe operation, Whirlpool®



Commercial washers feature a lid switch that is truly hidden. Prevents tampering and ensures the washer will not operate when the lid is open.

High and Low Water Level Reduce Water Consumption to 25.22 Gallons Per Cycle*

*Based on low water level, 3 lb. load

On Premise Non-Metered Commercial Washer



Featuring Mechanical Controls

Whirlpool® On-Premise Non-Metered Commercial Washer Mechanical Controls

WASHER SPECIFICATIONS	
MODEL	GCAM2792TQ
GENERAL INFORMATION	
Stainless steel look push button console, powdered finish cabinet, top and lid galvanized, extra thick back panel, reliable dual agitator inlet hoses and corrugated drain hoses included	8-Cycles: Regular/Super, Regular/Heavy, Regular/Normal, Regular/Light, Permanent Press/Normal, Permanent Press/Light, Gentle, Extra Rinse
BASKET VOLUME	3.2 Cu. Ft.
MOTOR	
120-Volt ½ HP Direct Drive with Built-In Overload Protector	2-Speed
Motor RPM	1725 High
Spin RPM	640 High
AGITATION STROKES PER MINUTE/AMPERAGE Maximum Rated Amperage	180 SPM/High (5.0 Amps No Load) 9.8 Amps (120-Volt)
ELECTRICAL REQUIREMENTS	
	120V, 60Hz., A.C. Standard 15 Amp Breaker/Fuse Branch Circuit for Each Washer (Subject to Local Codes)
SHIPPING WEIGHT (EST.)	124 Lbs.
DIMENSIONS	
Width – in. (cm)	27 (68.5 cm)
Width – in. (cm)	27 (68.5 cm)
Height – in. (cm) at Metercase Top	43 (109 cm)
Height – in (cm) at Lid	35 (91 cm)

Energy information is available online at www.whirlpoolcommerciallaundry.com/products, WP literature part #CWXL077B

Dimensions are for planning purposes only. For complete information, see installation instructions packed with product.

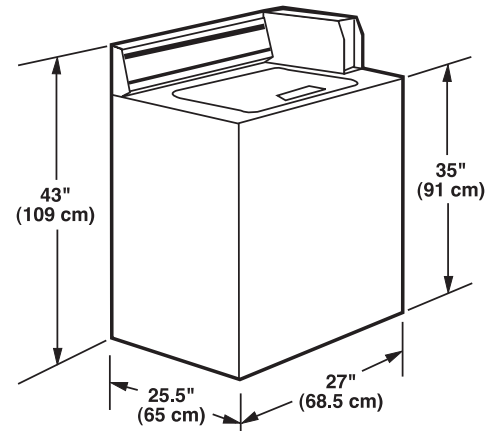

WASHER FRONT VIEW

NEW YORK CITY
M.E.A.

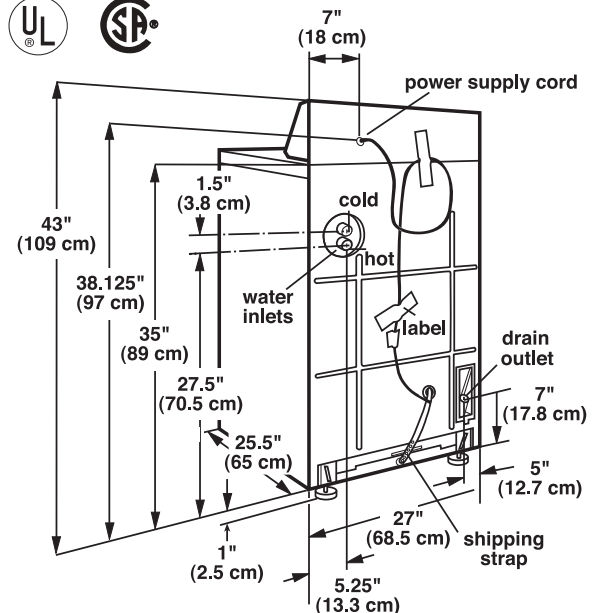

WASHER BACK VIEW



EXCLUSIVE 90-DAY FACTORY LABOR WARRANTY WASHER WARRANTY—2 YEAR LIMITED (PARTS ONLY)

For important information regarding warranty inclusions, exclusions and limitations, please call 1-800-NO-BELTS

To Locate a Distributor Near You, Please Visit www.whirlpoolcommerciallaundry.com/distributor, or call 1-800-NO-BELTS