

# HIGH-EFFICIENCY COMMERCIAL WASHER



Featuring Factory Installed Coin Slide and Coin Box



## CAM2752TQ—27" 2-Speed Washer

- 3.2 Cu. Ft. Wash Basket, 18 Lbs. UL
- Push-Button Controls
- High-Efficiency, Low Water Factor
- 3 Cycles: Heavy (Hot/Cold), Permanent Press (Warm/Cold) and Colorfast (Cold/Cold)
- 3 Cycle Indicator Lamps
- Two-Speed Advantage with True Gentle Wash, High Speed Spin Only
- Deep Rinse System, Automatic Temperature Control 115°H/85°W
- Porcelain Top and Lid, Rust-Proof Stainless Steel Torx® Control Panel Screws and Stainless Steel Hinges
- Galvanized, Heavy Gauge Cabinet Back, Side and Front Panels, Removable Front Service Panel
- High-Speed Spin – 640 RPM (approximate)
- Motor: 1/2-HP with Built-In Overload Protector: 120-Volt, 60 Hz., A.C. Agitation Speed 180 SPM/High 120 SPM/Low
- Heavy-Duty Motor Coupler Isolator Tested to 20,000 Cycles\*
- Extra-Long Power Cord and Commercial-Grade Color-Coded Water Inlet Hoses with Brass Couplings and EDPM Rubber Drain Hose
- Factory Coin Slide and Coin Box Equipped, \$1.50 Factory Preset Vend V8 Coin Slide
- **3 Years Limited Parts Only Warranty\*\***

\*Testing completed 11/12/2001

\*\*Call 1-800-NO-BELTS for warranty details.

### FOR YOUR CUSTOMERS

- Large Capacity Wash Basket is Ideal for Family-Size Loads
- 3 Cycle Options: Heavy, Permanent Press and Colorfast for a Wide Range of Fabrics

### DIRECT DRIVE SYSTEM

- 27" Heavy-Duty Commercial Washer Features the Reliable Direct-Drive, No-Belt Washing System for Greater Reliability, Reduced Downtime and Increased Profits
- Front and Bottom Serviceable

### TRIPOD SUSPENSION

Sturdy tripod-suspension with active liquid filled balance ring reduce product weight while balancing commercial size laundry loads.



### SEALED HIDDEN LID SWITCH

- Larger Coin Box for Reduced Collections
- Accepts Coin Slide, Coin-Drop and Card Reader Configurations

### FRONT LOCK READY

- Factory-Installed Lock Blank Provides a Visual Vandalism Deterrent
- Optional Front Panel Lock Assembly (Part #358290) For Added Security of Tying Front and Top Panels Together

Reduce Water Consumption to  
**23.22 Gallons per Cycle\***

\*Based on low water level, 3 lb. load

# HIGH-EFFICIENCY COMMERCIAL WASHER



## Featuring Factory Installed Coin Slide and Coin Box

### Whirlpool® High Efficiency Commercial Washer Factory Installed Coin Slide and Coin Box

WASHER SPECIFICATIONS	
<b>MODEL</b>	<b>CAM2752TQ</b>
<b>GENERAL INFORMATION</b>	
Factory installed coin slide and coin box. Set your wash price from \$0-\$2 per cycle (\$1.50 factory preset). Stainless steel look push button console, hidden lid switch, porcelain finish top and lid, galvanized, extra thick front panel, side and back panels, improved meter case, front panel lock blank factory installed. Commercial-Grade, color-coded, water inlet hoses with brass couplings and rubber drain hose included.	High Efficiency Deep Rinse, Electronic Temperature Control, Super Capacity 3.2 Cu. Ft. Basket, High and Low Water Level Settings
<b>BASKET VOLUME</b>	3.2 Cu. Ft. (18 Lbs. UL)
<b>MOTOR</b>	
120-Volt ½ HP Direct Drive with Built-In Overload Protector	Two-Speed Advantage with True Gentle Wash High Speed Spin Only
Motor RPM	1725 High, 1140 Low
Spin RPM	640 High
<b>AGITATION STROKES PER MINUTE/AMPERAGE</b>	180 SPM/High (5.0 Amps No Load) 120 SPM/Low (5.0 Amps No Load)
<b>MAXIMUM RATED CURRENT</b>	9.8 Amps (120-Volt)
<b>ELECTRICAL REQUIREMENTS</b>	120V, 60Hz., A.C. Standard 15 Amp Breaker/Fuse Branch Circuit for Each Washer
<b>SHIPPING WEIGHT (EST.)</b>	184 Lbs.
<b>DIMENSIONS</b>	
Width – in. (cm)	27 (68.5 cm)
Depth – in. (cm)	25.5 (65 cm)
Height – in. (cm) at Metercase Top	43 (109 cm)
Height – in. (cm) at Lid	35 (91 cm)

Energy information is available online at [www.whirlpoolcommerciallaundry.com/products](http://www.whirlpoolcommerciallaundry.com/products)

Dimensions are for planning purposes only. For complete information, see installation instructions packed with product.

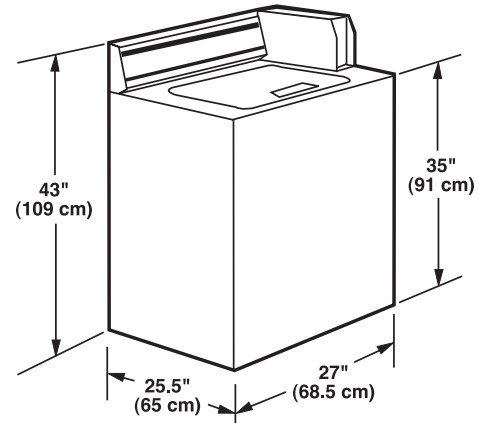

WASHER FRONT VIEW

NEW YORK CITY  
M.E.A.

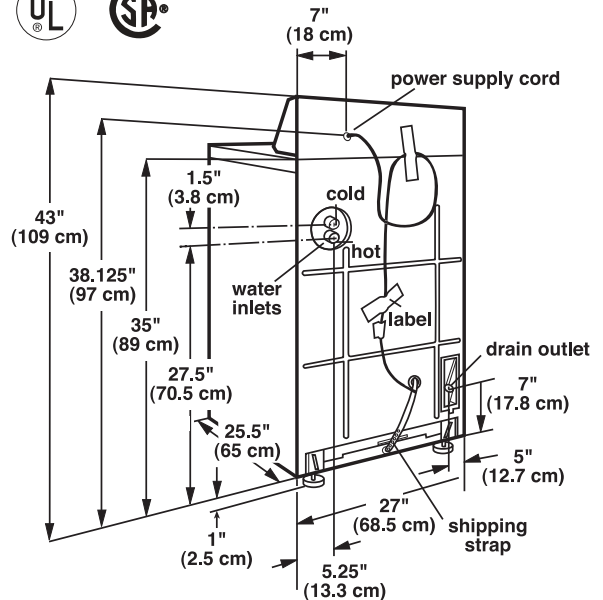

WASHER BACK VIEW

PIN	FUNCTION
5 to neutral	Remote cycle start with remote relay closures
1 to 4	Changes state every 30 seconds
3 to 6	Cycle counter

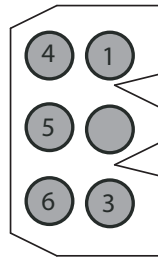

E-Z Wiring  
Harness Feature  
Connector for  
connection to  
money acceptors  
(located under  
top cover)



### 3 YEARS LIMITED PARTS ONLY WARRANTY

For a period from the date of original purchase through the time listed above, the designated parts that fail in normal commercial use will be repaired or replaced free of charge for the part itself, with the owner paying all other costs, including labor, transportation and customs duty. Chemical damage is excluded from all warranty coverage. See complete warranty for details.

To Locate a Distributor Near You, Please Visit [www.whirlpoolcommerciallaundry.com/distributor](http://www.whirlpoolcommerciallaundry.com/distributor), or call 1-800-NO-BELTS