

HIGH-EFFICIENCY COMMERCIAL WASHER



Featuring Factory-Installed Coin Slide and Coin Box



FOR YOUR CUSTOMERS

- Large Capacity Wash Basket is Ideal for Family-Size Loads
- 3 Cycle Options: Heavy, Permanent Press and Colorfast for a Wide Range of Fabric

DIRECT DRIVE SYSTEM

- 27" Heavy-Duty Commercial Washer Feature the Reliable Direct-Drive, No-Belt Washing System for Greater Reliability, Reduced Downtime and Increased Profits
- Front and Bottom Serviceable

TRIPOD SUSPENSION

Sturdy tripod-suspension with active liquid filled balance ring reduces product weight while balancing commercial-size laundry loads.



CAM2742TQ 27" 2-Speed Washer

- 3.2 Cu. Ft. Wash Basket, 18 Lbs. UL
- Push-Button Controls
- High-Efficiency, Low Water Factor
- 3 Cycles: Heavy (Hot/Cold), Permanent Press (Warm/Cold) and Colorfast (Cold/Cold)
- 3 Cycle Indicator Lamps
- Two-Speed Advantage with True Gentle Wash, High-Speed Spin Only
- Deep Rinse System, Automatic Temperature Control 115°H/85°W
- Rust-Proof Stainless Steel Torx® Control Panel Screws
- Galvanized, Heavy Gauge Cabinet Back Panel
- High-Speed Spin – 640 RPM (approximate)
- Motor: 1/2-HP with Built-In Overload Protector: 120-Volt, 60 Hz., A.C. Agitation Speed 180 SPM/High 120 SPM/Low
- Heavy-Duty Motor Coupler Isolator Tested to 20,000 Cycles*
- Residential Grade Inlet Hoses and Corrugated Drain Hose Included
- Factory Coin Slide and Coin Box Equipped, \$1.50 Factory Preset Vend V8 Coin Slide
- **90-Day Labor/2 Years Limited Parts Warranty****

*Testing completed 11/12/2001
**Call 1-800-NO-BELTS for warranty details.

SEALED HIDDEN LID SWITCH

To help ensure safe operation, Whirlpool® Commercial Washers feature a lid switch that is truly hidden. Prevents tampering and ensures the washer will not operate when the lid is open.

Reduce Water Consumption to 23.22 Gallons per Cycle†

†Based on low water level, 3 lb. load



INDUSTRIAL STRENGTH WATER INLET HOSES

Tested to 1100 PSI.

HIGH-EFFICIENCY COMMERCIAL WASHER



Featuring Factory-Installed Coin Slide and Coin Box

Whirlpool® High-Efficiency Commercial Washer Mechanical Controls

WASHER SPECIFICATIONS	
MODEL	CAM2742TQ
GENERAL INFORMATION	
Stainless steel look push-button console, hidden lid switch, powdered paint finish top, lid and cabinet, galvanized back, improved metercase, inlet hoses and corrugated drain hose included	High-Efficiency Deep Rinse, Electronic Temperature Control, Super Capacity 3.2 Cu. Ft. Basket, High and Low Water Level Settings
BASKET VOLUME	3.2 Cu. Ft. (18 Lbs. UL)
MOTOR	
120-Volt ½-HP Direct Drive with Built-In Overload Protector	Two-Speed Advantage with True Gentle Wash High-Speed Spin Only
Motor RPM	1725 High, 1140 Low
Spin RPM	640 High
AGITATION STROKES PER MINUTE/AMPERAGE	
	180 SPM/High (5.0 Amps No Load) 120 SPM/Low (5.0 Amps No Load)
MAXIMUM RATED CURRENT WEIGHT (EST.)	9.8 Amps (120 Volt)
ELECTRICAL REQUIREMENTS	
	120V, 60Hz., A.C. Standard 15 Amp Breaker/Fuse Branch Circuit for Each Washer
SHIPPING WEIGHT (EST.)	184 Lbs.
DIMENSIONS	
Width – in. (cm)	27 (68.5 cm)
Depth – in. (cm)	25.5 (65 cm)
Height – in. (cm) at Metercase Top	43 (109 cm)
Height – in. (cm) at Lid	35 (91 cm)

Energy information is available online at www.whirlpoolcommerciallaundry.com/products.

Dimensions are for planning purposes only. For complete information, see installation instructions packed with product.

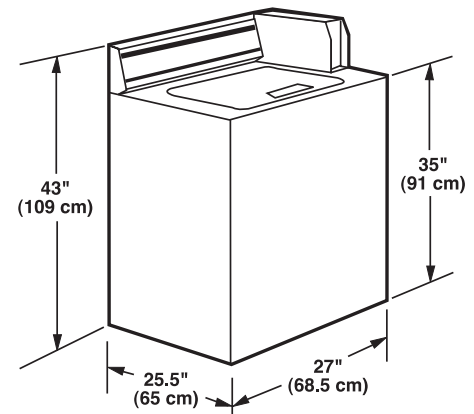

WASHER FRONT VIEW

NEW YORK CITY
M.E.A.

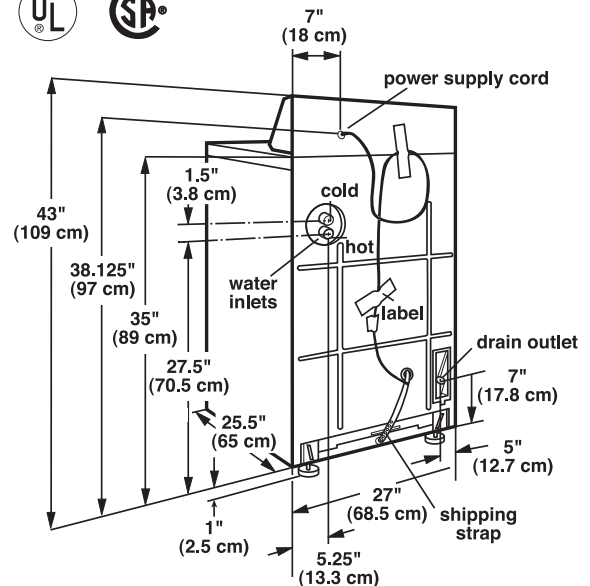

WASHER BACK VIEW

PIN	FUNCTION
5 to neutral	Remote cycle start with remote relay closures
1 to 4	Changes state every 30 seconds
3 to 6	Cycle counter

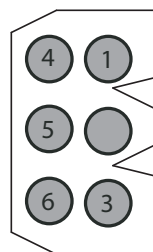

E-Z Wiring
Harness Feature
Connector for
connection to
money acceptors
(located under
top cover)



**EXCLUSIVE 90-DAY FACTORY
LABOR WARRANTY
WASHER WARRANTY—2 YEAR
LIMITED (PARTS ONLY)**

For important information regarding warranty inclusions, exclusions and limitations, please call 1-800-N0-BELTS.

To Locate a Distributor Near You, Please Visit www.whirlpoolcommerciallaundry.com/distributor, or call 1-800-N0-BELTS